



STEAM GENERATORS



Safe, Economic, Highly Productive and Environment Friendly



Less Fuel More Profit

ALBA Steam Generators use less fuel and are Economic.

ALBA Steam Generators are the perfect solution for any sector which is in need of steam. We supply textile, tourism, health care, energy, construction, chemical and food production facilities, which are just some examples of the vast application areas, with highly productive and safe steam.

The special design and ignition system enables less fuel consumption, fast, continuous steam and most importantly a non-explosive, 100% safe system. This unique generator is not only productive but also environmental friendly.

ALBA Steam Generator are being used today in a very wide range of application areas like big garment factories, 5 star luxury hotels, washing facilities, food factories, defense and military establishments.



Main features

- NO RISK OF EXPLOSION
- 92-94% productivity
- Low NOx emission values
- Ready-to-use steam in 3 minutes after a system start
- PC connection for real-time data analysis
- Visual tracking of all control data from main control panel
- Natural Gas, Diesel, LPG, LNG and Dual Fuel (Gas and Diesel) fuel options
- 24 Hours continuous technical service and direct spare part supply



Boiler Room Construction In Half a Day

ALBA Package System Steam Generators

Packet System steam generators enable a very fast ready-to-use construction of your boiler room. These package systems consist of two movable platforms. The combined system includes the steam generator, a water softening system, a condense tank, a circulation pump and By-Pass group. All these components are installed and connected together on two platforms. After moving the whole system into place an ALBA specialist can make final controls and start up the whole system within the same day.

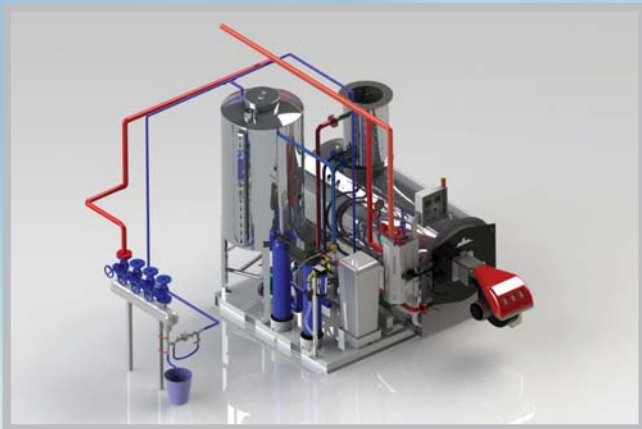

ALBA Cascade System Steam Generators

***The best solution for high capacity,
unit-time scalable steam needs***

ALBA, with its experienced team of engineers and technicians, focuses on individual customer needs and offers the most productive and economic solutions for systems. Cascade generator systems are equipped with fully modulating Riello burners and enable up to 50% fuel saving.

The principle of our cascade system is to Use exactly as much fuel as needed, not more. The system automatically controls the steam production over multiple generators to match the required steam quantity. This enables very efficient fuel saving and also treats every generator in the system as a back-up/substitute unit.

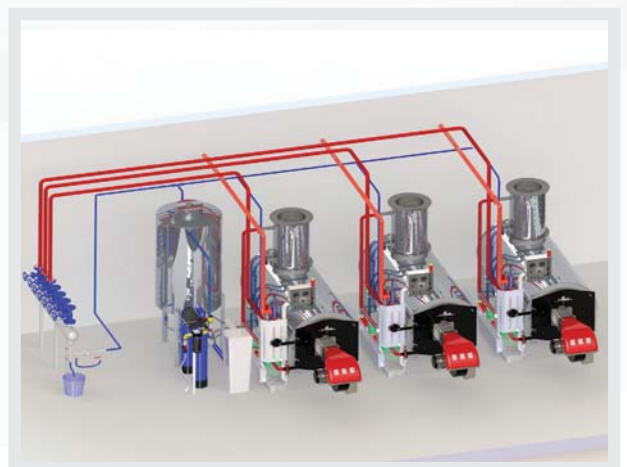

Why ALBA Steam Generators?

ALBA Steam Generator

In this day and age, profit is made by using energy efficiently and fast. ALBA uses this concept at the production process of generators, together with high-end technology. The correlation between the body, the coil and the ignition system shows the heat efficiency. The heat transfer between systems at different temperatures shows the efficiency and durability of the designed system. Considering these two statements, high speed heat exchange and ignition efficiency enables to receive the best results from energy.

ALBA Steam Generators are a product of thermodynamic calculations, high-tech production and unique assembly. The heart of the system consists of a coil which is specially designed for water flow efficiency and maximum heat exchange. The precision in the ignition system, the technology and design used to manufacture the coil, the overall quality of all equipment used shows the difference and advantage of ALBA steam generators. Ignition efficiency and fast heat exchange rates guarantee a PROFITABLE OUTCOME.

- *High efficient ignition system with Riello and Weisshaupt burners.*
- *Tenaris certified 12 meter long ST35.8 steel pipes are welded together with a Robotic Orbital welding machine and are coiled with a high-tech coiler.*
- *Horizontal models use a 3-Way coil system together with an Economizer as a standard. The economizer pre-heats incoming cold water to save even more fuel.*
- *Vertical models use a 4-Way coil system and a servo-motor technology that regulates air-fuel flow for high productivity.*
- *All body parts are electrostatic powder paint coated.*
- *The exterior of all generators are coated with Thyssen Cr-Ni stainless steel sheets.*
- *ALBA Makina after-sales offer 24/7 technical service and direct spare part supplies.*



Horizontal Steam Generator Technical Specifications

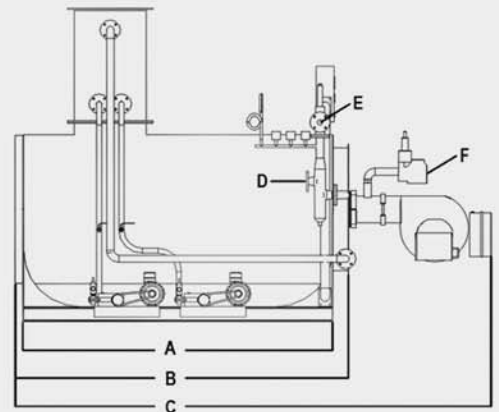
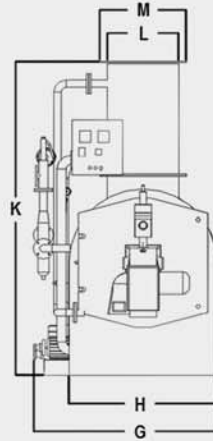
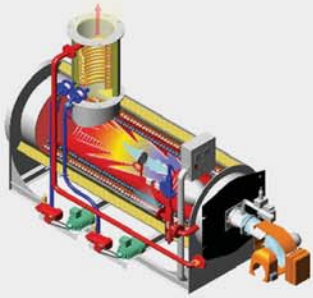

MODEL	A	B	C	D	E	F	G	H	K	L	M
	mm	mm	mm	DN	Inch	Inch	mm	mm	mm	mm	mm
D05 - 500	1400	1660	2235	DN40	1 1/2"	1 1/4"	1280	900	2090	365	530
D05 - 750	1900	2160	3030	DN50	1 1/2"	1 1/4"	1530	1100	2190	365	530
D05 - 1000	1900	2160	3030	DN50	2"	1 1/4"	1530	1100	2190	365	530
D05 - 1500	2400	2660	3620	DN65	2 1/2"	1 1/2"	1650	1200	2290	445	650
D05 - 2000	2400	2660	3910	DN65	3"	2"	1650	1200	2290	445	650
D05 - 2500	2800	3060	4310	DN80	3"	2"	2175	1350	2310	445	650
D05 - 3000	2900	3160	4410	DN100	3"	2"	2100	1260	2310	445	650
D05 - 3500	3600	3860	5245	DN100	3"	2"	2305	1500	2420	445	650
D05 - 4000	3600	3860	5245	DN125	3"	3"	2340	1510	2700	445	650
D05 - 4500	4500	4760	6145	DN125	3"	3"	2730	1900	3000	445	650
D05 - 5000	4500	4760	6145	DN125	3"	3"	2930	2100	3000	445	650

Dimensions and data above is with respect to Natural Gas fuel

D: Steam Outlet **E:** Safety Valve **F:** Gas Inlet **L:** Inner Chimney Diameter **M:** Outer Chimney Diameter

STEAM CAPACITY	Capacity	Capacity	Weight	Counter Pressure	Power	Sound Level
	kCal/h	kW	Ton	mbar	kW	dbA
500 Kg/h	300.000	348,83	1,1	0,51	1,42	70
750 Kg/h	450.000	523,25	1,8	0,44	2,7	72
1000 Kg/h	600.000	697,67	1,9	0,39	2,7	73
1500 Kg/h	900.000	1.046,51	2,5	0,32	3,85	75
2000 Kg/h	1.200.000	1.395,34	2,8	0,27	6,8	77
2500 Kg/h	1.500.000	1.744,18	3,1	0,24	6,8	77,5
3000 Kg/h	1.800.000	2.093	4,1	0,21	12,4	78
3500 Kg/h	2.100.000	2.441,86	4,5	0,18	13,2	79
4000 Kg/h	2.400.000	2.790,69	5,3	0,16	14	80
4500 Kg/h	2.700.000	3.139,53	5,5	0,14	14	80
5000 Kg/h	3.000.000	3.488,37	5,8	0,13	23,5	80

Vertical Steam generator Technical Specifications

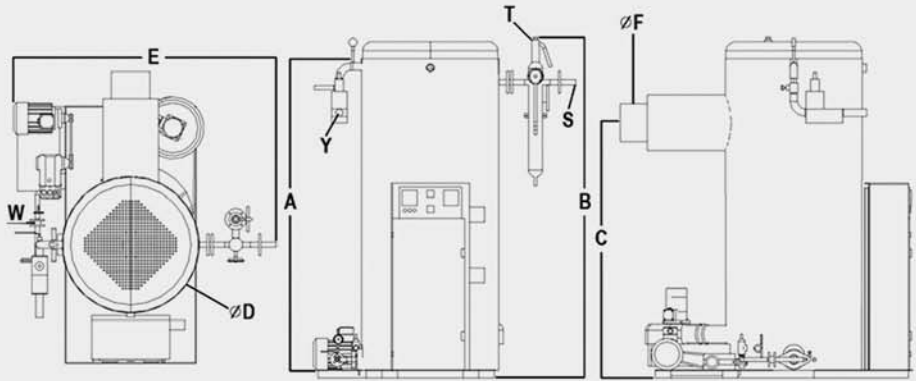
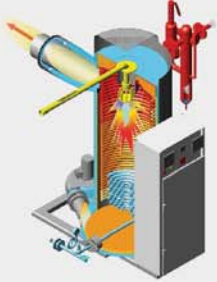

MODEL	A	B	C	D	E	F	S	Y	W	T
	mm	mm	mm	mm	mm	mm	Inch	Inch	Inch	Inch
D03 - 150	1435	1500	1035	575	1200	190	½"	1"	½"	¾"
D03 - 350	1700	1800	1350	710	1250	230	1"	1"	¾"	¾"
D03 - 500	1700	1800	1350	710	1250	230	1"	1¼"	¾"	¾"
D03 - 750	1900	2000	1510	810	1420	310	1¼"	1¼"	¾"	1"
D03 - 1000	2150	2250	1760	860	1650	310	1¼"	1½"	1"	1 ¼"
D03 - 1200	2150	2250	1760	860	1650	310	1½"	1½"	1"	1 ¼"
D03 - 1500	2250	2350	1850	1000	1800	350	1½"	2"	1"	1 ¼"

Dimensions and data above is with respect to Natural Gas fuel
F: Chimney Dimension **S:** Steam Outlet **Y:** Gas Inlet **W:** Water Inlet **T:** Safety Valve

STEAM CAPACITY	Capacity	Capacity	Weight	Counter Pressure	Power	Sound Level
	kCal/h	kW	Kg	mbar	kW	dbA
150 Kg/h	90000	104,65	280	1,3	1,8	70
350 Kg/h	210000	244,18	480	1,7	3,25	73
500 Kg/h	300000	348,83	480	1,7	3,45	74
750 Kg/h	450000	523,25	925	2	4,9	75,5
1000 Kg/h	600000	697,67	1.200	2,3	5,7	77
1200 Kg/h	720000	837,21	1.400	2,4	5,7	77
1500 Kg/h	900000	1.046,51	1.750	3,1	5,7	77

Electrical Steam Producers



D01 Electrical Steam Boiler

- Compatible with any system that needs steam
- Fast and continuous steam
- High quality Safety Valves
- Electrical discharges and high pressure steam causes the main circuit to switch to safety.
- Double pressure controllers

D02 Mini Steam boiler

- Compatible with any system that needs steam
- Fast and continuous steam
- High quality Safety Valves
- Double pressure controllers
- Stainless Steel boiler
- Bronze pump holders



MODEL	Power	Steam Capacity	Working Pressure	Heaters	Dimensions
	kW	kg/h	bar	adet	mm
D02	4,5	6	3	1	365 x 405 x 875
D02-1	9	12	3	2	380 x 270 x 330
D01-1	15	20	4	2	675 x 675 x 990
D01-2	30	40	4	4	670 x 670 x 1300
D01-3	45	61	4	6	850 x 733 x 1300
D01-4	60	78	4	8	875 x 875 x 1285
D01-5	75	98	4	10	1050 x 1290 x 1650

ABOUT US



Alba Makina Co. Ltd. was founded in 1969 and started manufacturing dry cleaning and ironing machines. The company owners Cengiz and Nafiz Albayrak constructed a production factory of 3.500 sqm at the period in which textile and garment finishing machines were high in demand in Turkey. With this factory, Alba Makina has always been the leading company in its branch. Turkey's first Robotic Ironing Machines, Computer Controlled Ironing Presses and Steam Generators have been produced by Alba Makina.



At the beginning of the 90's, a new 20.000 sqm factory was built 180 km outside Istanbul is the main production plant still today. New set goals and investments enabled Alba Makina to revolutionize its industrial ironing and steam producers and deliver

better and more original machines to the market than its rivals. To maintain, and even take customer services and physical aspects to a new level Alba Makina grounded their 7.500 sqm Head Office at the heart of the thriving commercial city of Istanbul.

Reinforcing their production with High-Tech production machines enabled Alba Makina to enchant their product range with ergonomic and high end technology solutions.

Alba Makina provides with more than 35 years of experience in garment finishing technology, high-tech products, consulting and qualified service to the textile and garment industry. As a result of this, Alba Makina is the market leading company in Turkey and is one of the best International companies around the globe today.



REFERENCES



Head Office

Halkalı Caddesi Seher Sokak No: 1
Güneşli / İstanbul
Phone : +90 212 656 86 06
Fax : +90 212 515 12 22

Office

İMÇ 2. Blok No: 2351 Unkapanı / İstanbul
Phone : +90 212 526 03 85

Office

Ehli Beyt Mah. Cehun Atıf Kansu Cad.
Beycanoğlu İş Merkezi No: 104 H Balgat / Ankara
Phone : +90 312 473 72 47-48

Office

Ulubatlı Hasan Bulvarı No: 69/1 Bursa
Phone : +90 224 256 32 86

www.albamakina.com / alba@albamakina.com